

Vis à tête hexagonale avec filetage complet. C'est une vis de haute qualité en acier 8.8 de qualité. à appliquer avec une clé à douille hexagonale ou toute autre clé qui accepte les boulons hexagonaux.

MATÉRIEL: Acier au carbone haute résistance
FINITION: Huile antirouille
DURETÉ: 255-335 HV

Mesure M x L	Référence	a Max.	e Min.	k Max.	s Max.	P Pas de Fil	Couple serrage N/m	Boitage
6 x 16	04250371	3,0	11,05	4,15	10	1,0	9,3	200
6 x 20	04250391	3,0	11,05	4,15	10	1,0	9,3	200
6 x 25	04250411	3,0	11,05	4,15	10	1,0	9,3	200
6 x 30	04250421	3,0	11,05	4,15	10	1,0	9,3	200
6 x 35	04250431	3,0	11,05	4,15	10	1,0	9,3	200
6 x 40	04250441	3,0	11,05	4,15	10	1,0	9,3	200
6 x 45	04250451	3,0	11,05	4,15	10	1,0	9,3	200
6 x 50	04250461	3,0	11,05	4,15	10	1,0	9,3	200
6 x 60	04250481	3,0	11,05	4,15	10	1,0	9,3	200
8 x 16	04250771	3,75	14,38	5,45	13	1,25	22	200
8 x 18	04250781	3,75	14,38	5,45	13	1,25	22	200
8 x 20	04250791	3,75	14,38	5,45	13	1,25	22	200
8 x 25	04250811	3,75	14,38	5,45	13	1,25	22	200
8 x 30	04250821	3,75	14,38	5,45	13	1,25	22	200
8 x 40	04250841	3,75	14,38	5,45	13	1,25	22	200
8 x 50	04250861	3,75	14,38	5,45	13	1,25	22	200
8 x 55	04250871	3,75	14,38	5,45	13	1,25	22	200
8 x 60	04250881	3,75	14,38	5,45	13	1,25	22	200
8 x 70	04250901	3,75	14,38	5,45	13	1,25	22	200
8 x 80	04250921	3,75	14,38	5,45	13	1,25	22	200

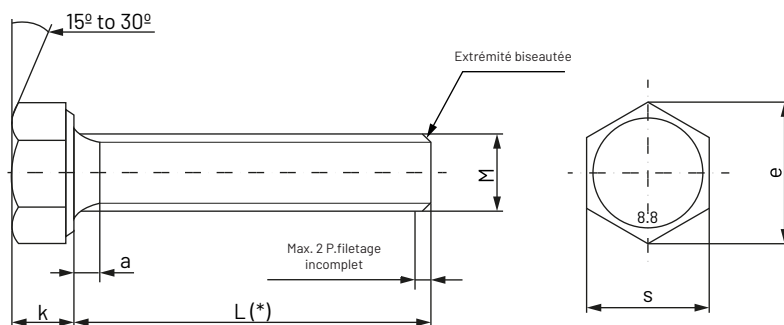

Mesure M x L	Référence	a Max.	e Min.	k Max.	s Max.	P Pas de Fil	Couple serrage N/m	Boîlage
10 x 16	04250971	4,50	18,90	6,58	17	1,5	45	200
10 x 20	04250991	4,50	18,90	6,58	17	1,5	45	200
10 x 25	04251011	4,50	18,90	6,58	17	1,5	45	200
10 x 30	04251021	4,50	18,90	6,58	17	1,5	45	200
10 x 35	04251031	4,50	18,90	6,58	17	1,5	45	200
10 x 40	04251041	4,50	18,90	6,58	17	1,5	45	200
10 x 50	04251061	4,50	18,90	6,58	17	1,5	45	200
10 x 55	04251071	4,50	18,90	6,58	17	1,5	45	200
10 x 60	04251081	4,50	18,90	6,58	17	1,5	45	200
10 x 70	04251101	4,50	18,90	6,58	17	1,5	45	200
10 x 80	04251121	4,50	18,90	6,58	17	1,5	45	100
12 x 20	04251181	5,25	21,10	7,68	19	1,75	77	200
12 x 25	04251201	5,25	21,10	7,68	19	1,75	77	200
12 x 30	04251211	5,25	21,10	7,68	19	1,75	77	200
12 x 35	04251221	5,25	21,10	7,68	19	1,75	77	200
12 x 40	04251231	5,25	21,10	7,68	19	1,75	77	200
12 x 45	04251241	5,25	21,10	7,68	19	1,75	77	200
12 x 50	04251251	5,25	21,10	7,68	19	1,75	77	100
12 x 60	04251271	5,25	21,10	7,68	19	1,75	77	100
12 x 70	04251291	5,25	21,10	7,68	19	1,75	77	100
12 x 80	04251311	5,25	21,10	7,68	19	1,75	77	100

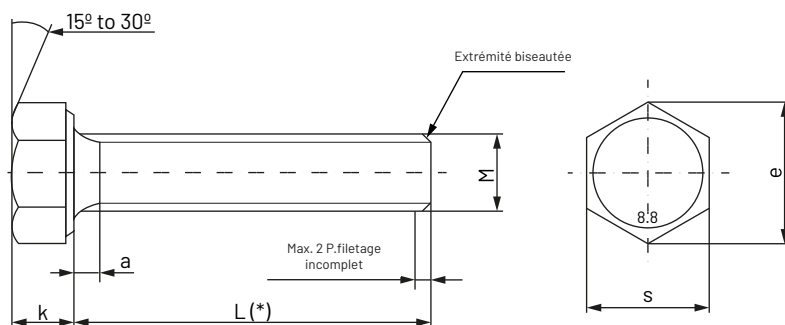

Mesure M x L	Référence	a Max.	e Min.	k Max.	s Max.	P Pas de Fil	Couple serrage N/m	Boîtage
14 x 30	04251401	6	24,49	8,98	22	2	125	200
14 x 35	04251411	6	24,49	8,98	22	2	125	200
14 x 40	04251421	6	24,49	8,98	22	2	125	100
14 x 45	04251431	6	24,49	8,98	22	2	125	100
14 x 50	04251441	6	24,49	8,98	22	2	125	100
14 x 60	04251461	6	24,49	8,98	22	2	125	100
14 x 65	04251471	6	24,49	8,98	22	2	125	50
14 x 70	04251481	6	24,49	8,98	22	2	125	50
14 x 80	04251501	6	24,49	8,98	22	2	125	100
16 x 30	04251561	6	26,75	10,18	24	2	190	100
16 x 35	04251571	6	26,75	10,18	24	2	190	100
16 x 40	04251581	6	26,75	10,18	24	2	190	100
16 x 45	04251591	6	26,75	10,18	24	2	190	100
16 x 50	04251601	6	26,75	10,18	24	2	190	50
16 x 60	04251621	6	26,75	10,18	24	2	190	50
16 x 65	04251631	6	26,75	10,18	24	2	190	50
16 x 70	04251641	6	26,75	10,18	24	2	190	50
16 x 80	04251661	6	26,75	10,18	24	2	190	50

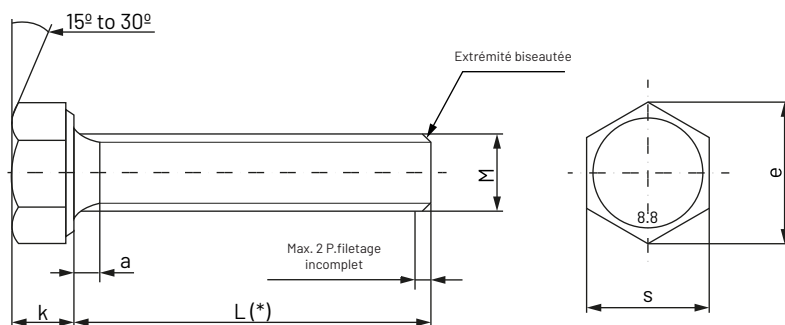

Mesure M x L	Référence	a Max.	e Min.	k Max.	s Max.	P Pas de Fil	Couple serrage N/m	Boitage
18 x 40	04251711	7,5	30,14	11,72	27	2,5	270	50
18 x 50	04251731	7,5	30,14	11,72	27	2,5	270	50
18 x 60	04251751	7,5	30,14	11,72	27	2,5	270	50
18 x 70	04251771	7,5	30,14	11,72	27	2,5	270	50
18 x 80	04251791	7,5	30,14	11,72	27	2,5	270	50
20 x 40	04251841	7,5	35,53	12,72	30	2,5	380	50
20 x 50	04251861	7,5	35,53	12,72	30	2,5	380	50
20 x 60	04251881	7,5	35,53	12,72	30	2,5	380	50
20 x 65	04251891	7,5	35,53	12,72	30	2,5	380	50
20 x 70	04251901	7,5	35,53	12,72	30	2,5	380	50
20 x 80	04251921	7,5	35,53	12,72	30	2,5	380	25
22 x 50	04251971	7,5	35,72	14,22	32	2,5	515	25
22 x 60	04251991	7,5	35,72	14,22	32	2,5	515	25
22 x 70	04252011	7,5	35,72	14,22	32	2,5	515	25
22 x 80	04252031	7,5	35,72	14,22	32	2,5	515	25
24 x 50	04252081	9	39,98	15,22	36	3	655	25
24 x 60	04252101	9	39,98	15,22	36	3	655	25
24 x 70	04252121	9	39,98	15,22	36	3	655	25
24 x 80	04252141	9	39,98	15,22	36	3	655	25

Longueur de la vis L(*)

Mesure	Min.	Max.	Mesure	Min.	Max.	Mesure	Min.	Max.
16	15,65	16,35	45	44,50	45,50	55	54,40	55,60
18	17,65	18,35	50	49,50	50,50	60	59,40	60,60
20	19,58	20,42	55	54,40	55,60	65	64,40	65,60
25	24,58	25,42	60	59,40	60,60	70	69,40	70,60
30	29,58	30,42	65	64,40	65,60	80	79,40	80,60
35	34,50	35,50	70	69,40	70,60			
40	39,50	40,50	80	79,40	80,60			