

Las abrazaderas P-Clip SMS están especialmente recomendadas para los trabajos de sujeción de tubos de plástico y mangueras en aplicaciones de sectores como la construcción, sanitario y la automoción. Usadas habitualmente en diferentes tipos de maquinaria agrícola, construcción de barcos y vehículos comerciales.

El perfil en caucho EPDM asegura una buena sujeción eliminando la vibración y evitando el daño que se pudiera causar en la zona de sujeción. A diferencia de la P-Clip DIN 3016, la P-Clip SMS tiene un agujero frontal ovalado y el agujero posterior redondo que permite una flexibilidad en el momento de la sujeción.

**MATERIAL:** W1 Acero inoxidable  
S350+Z275  
**RESISTENCIA A LA CORROSIÓN:** 144 horas de niebla salina (ASTM B-117)

Las abrazaderas P-Clip SMS se presentan en dos anchos de cinta 12,7 mm (tornillo M6) y 15,9 mm (tornillo M8).

\* Diámetros especiales disponibles bajo pedido.

Denominación	Referencia	Ø D ±0.4	E ±0.4	T ±0.1	Envase	Embalaje
SMS 4/12	03025007	4,8	15,4	0,8	500	2.000
SMS 6/12	03025015	6,4	16,2	0,8	500	500
SMS 7/12	03025022	7,9	17,0	0,8	500	500
SMS 9/12	03025066	9,5	17,8	0,8	500	500
SMS 10/12	03025067	10,0	18,0	0,8	500	500
SMS 11/12	03025069	11,1	18,6	0,8	500	500
SMS 12/12	03025077	12,7	19,4	1,0	200	200
SMS 13/12	03025082	13,0	19,6	1,0	200	200
SMS 14/12	03025090	14,3	20,2	1,0	200	200
SMS 15/12	03025106	15,9	21,0	1,0	200	800
SMS 17/12	03025122	17,5	21,8	1,0	200	800
SMS 19/12	03025144	19,0	22,6	1,0	200	200
SMS 20/12	03025155	20,6	23,4	1,0	200	200
SMS 22/12	03025169	22,2	24,2	1,0	100	100
SMS 23/12	03025185	23,8	25,0	1,0	100	100

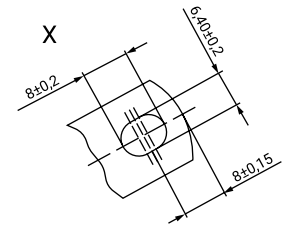
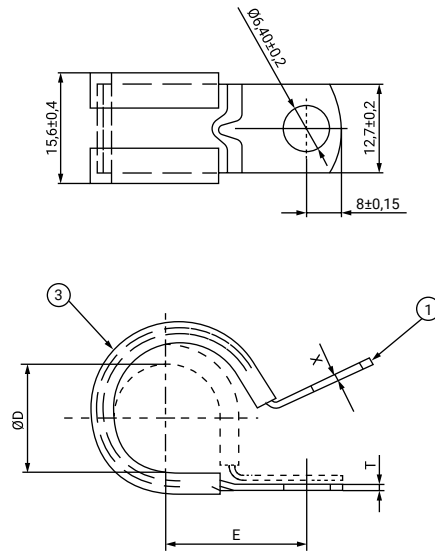

Denominación	Referencia	Ø D ±0.4	E ±0.4	T ±0.1	Envase	Embalaje
SMS 25/12	03025177	25,4	25,8	1,0	200	200
SMS 27/12	03025225	27,0	27,1	1,2	100	100
SMS 28/12	03025235	28,6	27,9	1,2	100	100
SMS 30/12	03025255	30,2	28,6	1,2	100	100
SMS 31/12	03025266	31,8	29,4	1,2	100	100
SMS 33/12	03025274	33,3	30,2	1,2	100	100
SMS 34/12	03025293	34,9	31,0	1,2	100	100
SMS 36/12	03025310	36,5	31,8	1,2	100	100
SMS 38/12	03025330	38,1	32,6	1,2	100	100
SMS 41/12	03025360	41,0	34,0	1,2	100	100
SMS 44/12	03025390	45,0	36,0	1,2	50	50
SMS 47/12	03025422	47,0	36,5	1,2	50	50
SMS 51/12	03025466	51,0	39,0	1,2	50	50
SMS 54/12	03025499	54,0	41,5	1,2	50	50
SMS 60/12	03025366	60,0	43,5	1,2	50	50
SMS 65/12	03025377	65,0	46,1	1,2	50	50
SMS 74/12	03025477	74,0	50,0	1,2	25	25
SMS 82/12	03025480	82,0	59,0	1,2	25	25
SMS 110/12	03025500	110,0	68,0	1,2	50	50

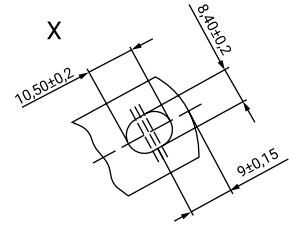
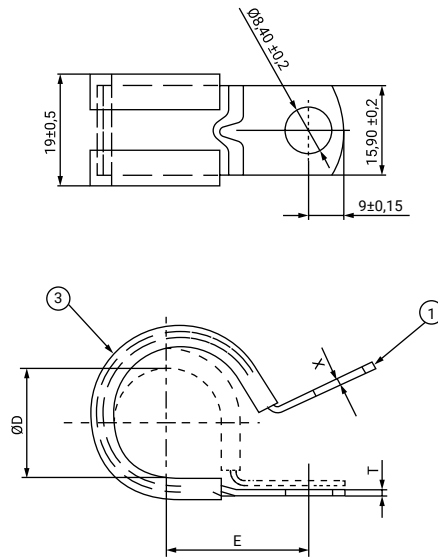

Denominación	Referencia	Ø D ±0.4	E ±0.4	T ±0.1	Envase	Embalaje
SMS 6/15	03025600	6,4	16,2	0,8	500	500
SMS 7/15	03025611	7,9	17,0	0,8	500	500
SMS 9/15	03025622	9,5	17,8	0,8	200	200
SMS 11/15	03025633	11,1	18,6	0,8	200	200
SMS 12/15	03025644	12,7	19,4	1,0	200	200
SMS 14/15	03025655	14,3	20,2	1,0	200	200
SMS 15/15	03025666	15,9	21,0	1,0	200	200
SMS 17/15	03025677	17,5	21,8	1,0	200	200
SMS 19/15	03025688	19,0	22,6	1,0	200	200
SMS 20/15	03025699	20,6	23,4	1,0	200	200
SMS 22/15	03025700	22,2	24,2	1,0	100	100
SMS 23/15	03025711	23,8	25,0	1,0	100	100
SMS 25/15	03025722	25,4	25,8	1,0	100	100
SMS 27/15	03025733	27,0	27,1	1,2	100	100
SMS 30/15	03025744	30,2	28,6	1,2	100	100
SMS 31/15	03025755	31,8	29,4	1,2	100	100
SMS 33/15	03025766	33,3	30,2	1,2	100	100
SMS 35/15	03025777	34,9	31,0	1,2	100	100
SMS 36/15	03025788	36,5	31,8	1,2	100	100
SMS 38/15	03025799	38,1	32,6	1,2	50	50
SMS 40/15	03025800	40,0	33,5	1,2	50	50
SMS 41/15	03025811	41,0	34,0	1,2	50	50
SMS 44/15	03025822	44,0	35,5	1,2	50	50
SMS 45/15	03025833	45,0	36,0	1,2	100	100
SMS 47/15	03025844	47,0	36,5	1,2	100	100
SMS 51/15	03025855	51,0	39,0	1,2	50	50
SMS 55/15	03025866	55,0	42,0	1,2	50	50
SMS 60/15	03025877	60,0	43,5	1,2	50	50
SMS 64/15	03025888	64,0	45,6	1,2	50	50
SMS 75/15	03025899	75,0	50,5	1,2	25	25
SMS 110/15	03025900	110,0	68,0	1,2	50	50