

Threaded rod made of high-quality steel that supports high tightening torques. It has a socket and knurled end for better grip. Its upper hole is hexagonal. It must be applied with a hexagonal key. As it does not have a head, once applied it is levelled with the surface where it has been installed.

MATERIAL: Alloy steel 34Cr4 (1.7033)
FINISH: Blued and anti-rust oil-dipped
HARDNESS: 45-53 HRC / 450-560 HV

Size M x L	Part Number	ØE Max. - Min.	ØF Max. - Min.	ØG Max. - Min.	e Min.	S Nominal	t Min.	P Thread pitch	Torque N/m	Box Quantity	Outer Box Quantity
3 x 3	01157005	2,98-2,87	2,36-2,25	1,40-1,15	1,73	1,50	1,20	0,5	0,9	1.000	64.000
3 x 4	01157013	2,98-2,87	2,36-2,25	1,40-1,15	1,73	1,50	1,20	0,5	0,9	1.000	64.000
3 x 5	01157021	2,98-2,87	2,36-2,25	1,40-1,15	1,73	1,50	2,00	0,5	0,9	1.000	64.000
3 x 6	01157030	2,98-2,87	2,36-2,25	1,40-1,15	1,73	1,50	2,00	0,5	0,9	1.000	64.000
3 x 8	01157048	2,98-2,87	2,36-2,25	1,40-1,15	1,73	1,50	2,00	0,5	0,9	1.000	64.000
3 x 10	01157056	2,98-2,87	2,36-2,25	1,40-1,15	1,73	1,50	2,00	0,5	0,9	1.000	32.000
3 x 12	01157064	2,98-2,87	2,36-2,25	1,40-1,15	1,73	1,50	2,00	0,5	0,9	1.000	32.000
3 x 16	01157072	2,98-2,87	2,36-2,25	1,40-1,15	1,73	1,50	2,00	0,5	0,9	1.000	16.000
4 x 4	01157080	3,97-3,83	3,11-2,97	2,00-1,75	2,30	2,00	1,50	0,7	2,5	1.000	64.000
4 x 5	01157099	3,97-3,83	3,11-2,97	2,00-1,75	2,30	2,00	1,50	0,7	2,5	1.000	64.000
4 x 6	01157101	3,97-3,83	3,11-2,97	2,00-1,75	2,30	2,00	2,50	0,7	2,5	1.000	32.000
4 x 8	01157110	3,97-3,83	3,11-2,97	2,00-1,75	2,30	2,00	2,50	0,7	2,5	1.000	32.000
4 x 10	01157128	3,97-3,83	3,11-2,97	2,00-1,75	2,30	2,00	2,50	0,7	2,5	1.000	32.000
4 x 12	01157136	3,97-3,83	3,11-2,97	2,00-1,75	2,30	2,00	2,50	0,7	2,5	1.000	16.000
4 x 16	01157144	3,97-3,83	3,11-2,97	2,00-1,75	2,30	2,00	2,50	0,7	2,5	1.000	16.000
4 x 20	01157152	3,97-3,83	3,11-2,97	2,00-1,75	2,30	2,00	2,50	0,7	2,5	500	8.000
5 x 5	01157160	4,97-4,82	3,99-3,84	2,50-2,25	2,87	2,50	2,00	0,8	5	1.000	32.000
5 x 6	01157179	4,97-4,82	3,99-3,84	2,50-2,25	2,87	2,50	3,00	0,8	5	1.000	16.000
5 x 8	01157187	4,97-4,82	3,99-3,84	2,50-2,25	2,87	2,50	3,00	0,8	5	1.000	16.000
5 x 10	01157195	4,97-4,82	3,99-3,84	2,50-2,25	2,87	2,50	3,00	0,8	5	500	8.000
5 x 12	01157208	4,97-4,82	3,99-3,84	2,50-2,25	2,87	2,50	3,00	0,8	5	500	8.000
5 x 16	01157216	4,97-4,82	3,99-3,84	2,50-2,25	2,87	2,50	3,00	0,8	5	500	8.000
5 x 20	01157224	4,97-4,82	3,99-3,84	2,50-2,25	2,87	2,50	3,00	0,8	5	500	8.000

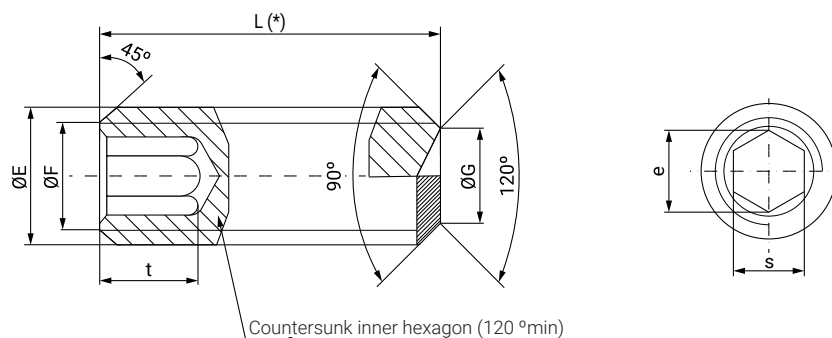

Size M x L	Part Number	ØE Max. - Min.	ØF Max. - Min.	ØG Max. - Min.	e Min.	S Nominal	t Min.	P Thread pitch	Torque N/m	Box Quantity	Outer Box Quantity
6 x 6	01157259	5,97-5,79	4,74-4,56	3,00-2,75	3,44	3,00	2,00	1,0	8,5	1.000	16.000
6 x 8	01157267	5,97-5,79	4,74-4,56	3,00-2,75	3,44	3,00	3,50	1,0	8,5	1.000	16.000
6 x 10	01157275	5,97-5,79	4,74-4,56	3,00-2,75	3,44	3,00	3,50	1,0	8,5	500	8.000
6 x 12	01157283	5,97-5,79	4,74-4,56	3,00-2,75	3,44	3,00	3,50	1,0	8,5	500	8.000
6 x 16	01157291	5,97-5,79	4,74-4,56	3,00-2,75	3,44	3,00	3,50	1,0	8,5	500	8.000
6 x 20	01157304	5,97-5,79	4,74-4,56	3,00-2,75	3,44	3,00	3,50	1,0	8,5	500	4.000
6 x 25	01157312	5,97-5,79	4,74-4,56	3,00-2,75	3,44	3,00	3,50	1,0	8,5	500	4.000
6 x 30	01157320	5,97-5,79	4,74-4,56	3,00-2,75	3,44	3,00	3,50	1,0	8,5	500	8.000
8 x 8	01157355	7,97-7,76	6,43-6,23	5,00-4,70	4,58	4,00	3,00	1,25	20	500	4.00
8 x 10	01157363	7,97-7,76	6,43-6,23	5,00-4,70	4,58	4,00	5,00	1,25	20	500	4.000
8 x 12	01157371	7,97-7,76	6,43-6,23	5,00-4,70	4,58	4,00	5,00	1,25	20	500	4.000
8 x 16	01157380	7,97-7,76	6,43-6,23	5,00-4,70	4,58	4,00	5,00	1,25	20	500	4.000
8 x 20	01157398	7,97-7,76	6,43-6,23	5,00-4,70	4,58	4,00	5,00	1,25	20	500	2.000
8 x 25	01157400	7,97-7,76	6,43-6,23	5,00-4,70	4,58	4,00	5,00	1,25	20	200	2.000
8 x 30	01157419	7,97-7,76	6,43-6,23	5,00-4,70	4,58	4,00	5,00	1,25	20	250	2.000
8 x 35	01157427	7,97-7,76	6,43-6,23	5,00-4,70	4,58	4,00	5,00	1,25	20	250	250
8 x 40	01157435	7,97-7,76	6,43-6,23	5,00-4,70	4,58	4,00	5,00	1,25	20	250	1.000

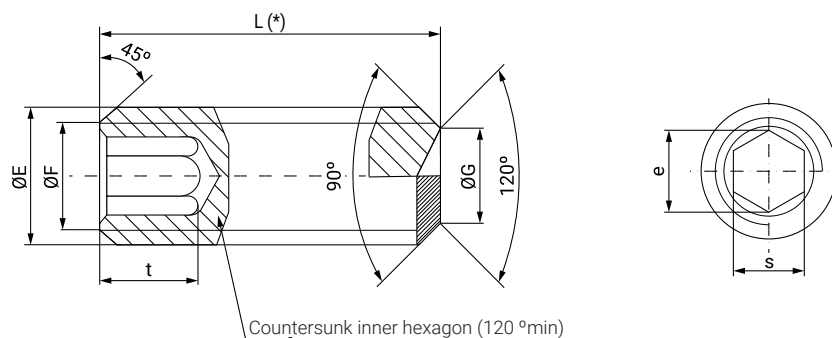

Size M x L	Part Number	ØE Max. - Min.	ØF Max. - Min.	ØG Max. - Min.	e Min.	S Nominal	t Min.	P Thread pitch	Torque N/m	Box Quantity	Outer Box Quantity
10 x 10	01157460	9,96-9,73	8,12-7,88	6,00-5,70	5,72	5,00	4,00	1,5	40	500	4.000
10 x 12	01157478	9,96-9,73	8,12-7,88	6,00-5,70	5,72	5,00	6,00	1,5	40	500	4.000
10 x 16	01157486	9,96-9,73	8,12-7,88	6,00-5,70	5,72	5,00	6,00	1,5	40	500	4.000
10 x 20	01157494	9,96-9,73	8,12-7,88	6,00-5,70	5,72	5,00	6,00	1,5	40	200	4.000
10 x 25	01157507	9,96-9,73	8,12-7,88	6,00-5,70	5,72	5,00	6,00	1,5	40	200	4.000
10 x 30	01157515	9,96-9,73	8,12-7,88	6,00-5,70	5,72	5,00	6,00	1,5	40	250	2.000
10 x 35	01157523	9,96-9,73	8,12-7,88	6,00-5,70	5,72	5,00	6,00	1,5	40	200	200
10 x 40	01157531	9,96-9,73	8,12-7,88	6,00-5,70	5,72	5,00	6,00	1,5	40	200	800
10 x 45	01157540	9,96-9,73	8,12-7,88	6,00-5,70	5,72	5,00	6,00	1,5	40	200	200
10 x 50	01157558	9,96-9,73	8,12-7,88	6,00-5,70	5,72	5,00	6,00	1,5	40	100	800
12 x 12	01157566	11,96-11,70	9,81-9,54	8,00-7,64	6,86	6,00	4,80	1,75	65	500	500
12 x 16	01157574	11,96-11,70	9,81-9,54	8,00-7,64	6,86	6,00	8,00	1,75	65	200	2.000
12 x 20	01157582	11,96-11,70	9,81-9,54	8,00-7,64	6,86	6,00	8,00	1,75	65	250	2.000
12 x 25	01157590	11,96-11,70	9,81-9,54	8,00-7,64	6,86	6,00	8,00	1,75	65	200	800
12 x 30	01157603	11,96-11,70	9,81-9,54	8,00-7,64	6,86	6,00	8,00	1,75	65	200	3.200
12 x 35	01157611	11,96-11,70	9,81-9,54	8,00-7,64	6,86	6,00	8,00	1,75	65	100	800
12 x 40	01157620	11,96-11,70	9,81-9,54	8,00-7,64	6,86	6,00	8,00	1,75	65	200	1.600
12 x 45	01157638	11,96-11,70	9,81-9,54	8,00-7,64	6,86	6,00	8,00	1,75	65	100	800
12 x 50	01157646	11,96-11,70	9,81-9,54	8,00-7,64	6,86	6,00	8,00	1,75	65	100	400

Screw length L(*)

Size	Min.	Max.	Size	Min.	Max.	Size	Min.	Max.
3	2,80	3,20	16	15,65	16,35	50	49,50	50,50
4	3,76	4,24	18	17,65	18,35	55	54,40	55,60
5	4,76	5,24	20	19,58	20,42	60	59,40	60,60
6	5,76	6,24	25	24,58	25,42	70	69,40	70,60
8	7,71	8,29	30	29,58	30,42	80	79,40	80,60
10	9,71	10,29	35	34,50	35,50	90	89,30	90,70
12	11,65	12,35	40	39,50	40,50	100	99,30	100,70
14	13,65	14,35	45	44,50	45,50			

Size tolerance M: 6g